

# Optimization of Composite Stiffened Cylindrical Shell using PSO Algorithm

M. Fakoore<sup>1</sup>, P. Mohammadzade<sup>2\*</sup> and E. Jafari<sup>3</sup>

1, 2, 3. Faculty of New Science and Technologies, University of Tehran

Postal code: 3456746, Tehran, Iran

mfakoore@ut.ac.ir

*Composite stiffened cylindrical shells are widely used as primary elements in aerospace structures. In the recent years, there has been a growing research interest in optimum design of composite stiffened cylindrical shell structures for stability under buckling load. This paper focuses upon the development of an efficient optimization of ring-stringer stiffened cylindrical shell. The optimization problem used in this study involves weight minimization of ring-stringer stiffened composite cylindrical shell with buckling load and stress, which are considered as design constraints. The proposed methodology is based on Particle Swarm Optimization (PSO) algorithm. The material of shell is composite, but the material of stiffeners is considered to be isotropic. The approach adopted in modeling utilizes the Rayleigh-Ritz energy method and the stiffeners are treated as discrete members. In addition, a 3-D Finite Element (FEM) model of the ring-stringer stiffened cylindrical shell is developed that takes into consideration the exact geometric configuration. The results obtained using the Rayleigh-Ritz energy method are compared with those using 3-D FE model. The proposed methodology is implemented on the ring-stringer stiffened cylindrical shell using the PSO algorithm. The obtained results show a 13% reduction in the weight of the ring-stringer stiffened cylindrical shell whilst all the design constraints are satisfied. In addition, the results show that the proposed methodology provides an effective way of solving composite stiffened cylindrical shell design problems.*

**Keywords:** Optimization, PSO algorithm, Cylindrical shell, Composites

## Introduction

Cylindrical shells are widely used in a variety of industries, including aerospace, marine, automotive, oil and gas. One of the main advantages of composite structures over the conventional structures is that the stiffness and strength of composite structures can be tailored by selecting orientation of fibers. In addition, significant weight reduction offered by composite materials makes composites a more attractive option in the design of cylindrical shells. In designing cylindrical shells with a minimum weight, the load bearing aspects of these structures will be generally constrained with a loss of stability under axial compression. Therefore, the buckling load and

the weight of structures are two main design considerations in their design [1]. In addition, the design flexibility offered by composites introduces additional design variables (e.g., fiber orientation, number and layer thickness) and the complex mechanical behavior of such materials make the design of composite structures a more difficult and time consuming process. These features of composites have motivated the use of optimization algorithms in the design of such structures, which has been the focus of many research programmers during the past two decades [2-5].

A survey paper by Ganguli [6] has provided a historical review of optimal design of composite structures and a study of composite structures with respect to industrial application has also been presented in [7]. Bruyneel [8] has presented a review of problems, solution procedures and applications of optimization of laminated

1. Professorm

2. Assistant Professor (Corresponding Authour)

3. M. Sc.

composite structures. In the recent years, there has been significant progress in the application of optimization on composite cylindrical shells [9-12].

Many researchers attempted to employ Genetic Algorithm (GA) in the optimization of composite structures [13-16]. Park et al. [17] have presented optimization of composite laminate stacking sequence by considering the uniform tensile axial loads to enhance strength using the theory of first-order transverse shear deformation based on Genetic Algorithm (GA). Gharib and Shakeri [18] have presented optimization of the stacking sequence of a laminated cylindrical shell with natural frequency and buckling load as the objective functions using GA and artificial neural networks (NN). Sadiqfar et al. [19] introduced GA in multi-objective optimization of stiffened cylindrical shells to achieve the minimum weight and maximum axial buckling load. Talebi et al. [20] proposed a novel tank design algorithm using GA for enhancing roll stability of fuel tank shape considering the multi-objective optimization of the problem. The main drawbacks of the use of GA in optimization of composite structures is a high number of evaluations required and the corresponding high computational time.

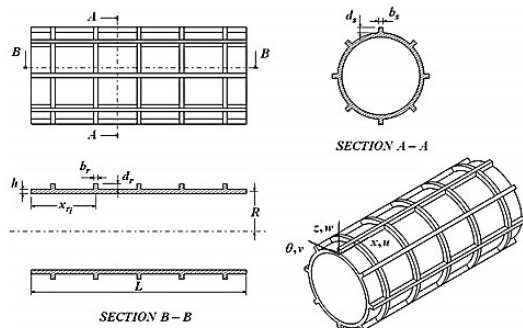

Fig. 1 Geometry of stiffened cylindrical shell

Particle swarm optimization (PSO) is a meta-heuristic optimization algorithm that is computationally more efficient than GA. This algorithm is an evolutionary algorithm introduced by Kennedy and Eberhart [21] and is inspired by the social behavior of animals such as fish and birds that live together in small and large groups. The fast convergence rate, the ease of implementation and the number of parameters set are other advantages of PSO [22-23]. Suresh et al. [24] has employed PSO as a multi-agent search method to maximize elastic coupling of a composite helicopter rotor blade. Chang et al. [25] introduced a method based on PSO for stacking sequence design. Some researchers used

PSO algorithm in the optimization problem of composite cylindrical shells.

This paper focuses on the optimization of composite stiffened cylindrical shell. The methodology presented in this paper involves the minimization of the weight of the stiffened cylindrical shell subjected to buckling and stress constraints as well as the side constraints of the design variables. The main motivations and contributions of this paper are: (I) development of an efficient optimization algorithm using PSO for optimum design of composite stiffened cylindrical shell, (II) comparative study of computational performance of GA and PSO on the composite stiffened cylindrical shell, (III) study of the effect of number of ring and stringer on buckling load, (IV) study of effect of  $L/R$  on buckling load.

$$\begin{aligned} u &= u_0(x, \theta) + z\varphi_x(x, \theta) \\ v &= v_0(x, \theta) + z\varphi_\theta(x, \theta) \\ w &= w_0(x, \theta) \end{aligned} \tag{1}$$

### Composite stiffened cylindrical shell equations

Consider a homogeneous circular cylindrical shell with thickness  $h$ , length  $L$ , mean radius  $R$ , mass density  $\rho$ , modulus of elasticity  $E$ , Poisson's ratio  $\nu$  and shear modulus  $G = E/2(1 + \nu)$ . The shell is reinforced by  $N$  rings of equal or unequal spacing and  $N_s$  stringers of equal spacing. A coordinate system  $(x, y, z)$  is fixed on the middle surface of the shell at one of its two ends, height of the stringer and the ring are shown with  $d_s$  and  $d_r$ , respectively, and the widths correspond to  $b_s$  and  $b_r$ . The intervals of the mid-shell to the geometric center of the stringer and the ring are marked with the  $z_s$  and  $z_r$  symbols, respectively. As shown in Fig. 1., the displacements of the different points of the shell are related to the displacements of mid surfaces by the Eq. 1. Where  $(u, v, w)$  are the orthogonal components of displacement of an arbitrary point  $(x, \theta, z)$  in the shell along the coordinates  $(x, \theta, z)$ , respectively, and  $(u_0, v_0, w_0)$  are the initial displacements of the shell mid-surface at point  $(x, \theta, z)$ . Shell strain energy could be stated as follows:

$$U_\varepsilon = \frac{1}{2} \int_0^L \int_0^{2\pi} \varepsilon^T [S] \varepsilon R d\theta dx \tag{2}$$

Where  $[S]$  is the stiffness matrix and  $R$  is mean radius. The strain vector,  $\varepsilon$  can be written as:

$$\varepsilon^T = \{ \varepsilon_x^0 \varepsilon_\theta^0 \gamma_{x\theta}^0 k_x k_\theta k_{x\theta} \} \tag{3}$$

$$\varepsilon_x^0 = u_{,x} \quad ; \quad \varepsilon_\theta^0 = \frac{1}{R}(v_{,\theta} + w) \quad ;$$

$$\gamma_{x\theta}^0 = \left( \frac{1}{R} u_{,\theta} + v_{,x} \right) \tag{4}$$

$$k_x = -w_{,xx} \quad ; \quad k_\theta = \frac{1}{R^2}(v_{,\theta} - w_{,\theta\theta})$$

$$k_{x\theta} = \frac{1}{R}(v_{,x} - 2w_{,x\theta})$$

Where  $\epsilon_x^0, \epsilon_\theta^0, \gamma_{x\theta}^0$  are the mean surface strains which are defined with the curvature of the middle surface  $k_x, k_\theta, k_{x\theta}$  in Equation 4.

According to the Love's first approximation:

To obtain the stiffened equations, the displacement according to the Euler-Bernoulli theory in the directions  $x, \theta, z$  are defined as follows:

$$\begin{aligned} u_0(x, \theta) &= A \cos(\lambda x) \cos(n\theta) \\ v_0(x, \theta) &= B \sin(\lambda x) \sin(n\theta) \quad \lambda = \frac{m\pi}{L} \\ w_0(x, \theta) &= C \sin(\lambda x) \cos(n\theta) \end{aligned} \quad (5)$$

$$\epsilon_{ss} = \frac{\partial u_0}{\partial x} - z \frac{\partial^2 w_0}{\partial x^2} \quad (6)$$

The strain in axial direction is stated as:

The strain in circumferential direction is stated as:

$$\epsilon_{rs} = \frac{1}{R} \left( \frac{\partial v_0}{\partial \theta} - \frac{z}{R} \frac{\partial^2 w_0}{\partial \theta^2} + w_0 \right) \quad (7)$$

And the strain energy of the rings is [26-27]:

$$\begin{aligned} U_r &= \sum_{K=1}^{N_r} \left[ \frac{1}{2} E_{rk} \int_0^L \int_{A_{rk}} \epsilon_{rs}^2 A_{rk} dx \right] \\ &+ \sum_{K=1}^{N_r} \left[ \frac{1}{2} G_{rk} J_{rk} \int_0^{2\pi} \frac{1}{R^2} \left( \frac{\partial^2 w_0}{\partial x \partial \theta} \right)^2 R dx \right] \end{aligned} \quad (8)$$

$G_{rk}, J_{rk}, A_{rk}, E_{rk}, N_r$  are torsional rigidity, polar moment of inertia, cross-section, elastic modulus and the number of rings, respectively.

The strain energy of the stringers is [28]:

$$\begin{aligned} U_s &= \sum_{K=1}^{N_s} \left[ \frac{1}{2} E_{sk} \int_0^L \int_{A_{sk}} \epsilon_{ss}^2 A_{sk} dx \right] \\ &+ \sum_{K=1}^{N_s} \left[ \frac{1}{2} G_{sk} J_{sk} \int_0^L \frac{1}{R^2} \left( \frac{\partial^2 w_0}{\partial x \partial \theta} \right)^2 dx \right] \end{aligned} \quad (9)$$

$G_{sk}, J_{sk}, A_{sk}, E_{sk}, N_s$  are torsional rigidity, polar moment of inertia, cross-section, elastic modulus, and the number of stringer, respectively.

Potential energy due to external forces including internal and external axial pressure are stated as follows:

Axial load [29]:

$$\begin{aligned} V_{Na} &= -\frac{N_a}{2} \int_0^L \int_0^{2\pi} \left[ \left( \frac{\partial u_0}{\partial x} \right)^2 + \left( \frac{\partial v_0}{\partial x} \right)^2 + \left( \frac{\partial w_0}{\partial x} \right)^2 \right] R^2 dx d\theta \end{aligned} \quad (10)$$

$N_a$  is axial loading.

Potential energy due to inner pressure [29]:

$$V_P = -\int_0^L \int_0^{2\pi} \frac{P}{2} \left\{ \left[ \frac{\partial^2 w_0}{\partial x^2} + w_0 \right] w_0 \right\} dx d\theta \quad (11)$$

Therefore, potential energy function could be written as follows:

$$\Pi = U_\epsilon + U_r + U_s + V_{Na} + V_P \quad (12)$$

Where  $U_\epsilon$  is shell strain energy,  $U_r$  is strain energy of the rings,  $U_s$  is strain energy of the stringers,  $V_{Na}$  is potential energy due to external forces and  $V_P$  is potential energy due to inner pressure.

Using the principle of minimum potential energy and Ritz method (minimizing the energy function relative to the Ritz function's coefficients), equilibrium equations can be obtained as follows:

$$\delta \Pi = 0 \Rightarrow \begin{cases} \frac{\partial \Pi}{\partial A} = 0 \\ \frac{\partial \Pi}{\partial B} = 0 \\ \frac{\partial \Pi}{\partial C} = 0 \end{cases} \quad (13)$$

To determine buckling load of the shell, Eq.13 can be rewritten as follows:

$$\begin{bmatrix} \alpha_{11} & \alpha_{12} & \alpha_{13} \\ \alpha_{21} & \alpha_{22} & \alpha_{23} \\ \alpha_{31} & \alpha_{32} & \alpha_{33} \end{bmatrix} \begin{Bmatrix} A \\ B \\ C \end{Bmatrix} = 0 \quad (14)$$

For Eq. 14 to have an unequivocal answer, the determinant of equation 15 must be zeroed:

$$\begin{vmatrix} \alpha_{11} & \alpha_{12} & \alpha_{13} \\ \alpha_{21} & \alpha_{22} & \alpha_{23} \\ \alpha_{31} & \alpha_{32} & \alpha_{33} \end{vmatrix} = 0 \quad (15)$$

The elements of the determinant are stated in Appendix (5). To calculate yield stresses, at first, the values of A, B and C are obtained by Eq. 14, then, by replacing the revalues into Eq.s 1 and 5, the displacement field will be achieved. After obtaining the displacements, by using Eq. 1, strains and curvature will be obtained. Employing Hooke's relation for orthotropic materials, the stresses are obtained for each laminate as follows:

$$\begin{Bmatrix} \sigma_x \\ \sigma_\theta \\ \tau_{x\theta} \end{Bmatrix} = \begin{bmatrix} \bar{Q}_{11} & \bar{Q}_{12} & \bar{Q}_{16} \\ \bar{Q}_{21} & \bar{Q}_{22} & \bar{Q}_{26} \\ \bar{Q}_{61} & \bar{Q}_{62} & \bar{Q}_{66} \end{bmatrix} \left\{ \begin{Bmatrix} \epsilon_x^0 \\ \epsilon_\theta^0 \\ \gamma_{x\theta}^0 \end{Bmatrix} + z \begin{Bmatrix} k_x \\ k_\theta \\ k_{x\theta} \end{Bmatrix} \right\} \quad (16)$$

Eq.16 can be used for any point of the shell. Strain equations are employed to calculate stress in rings and stringers as follows:

$$\sigma_r = \frac{E_r}{R} \left( \frac{\partial v_0}{\partial \theta} - \frac{z}{R} \frac{\partial^2 w_0}{\partial \theta^2} + w_0 \right) \quad (17)$$

$$\sigma_s = E_s \left( \frac{\partial u_0}{\partial x} - z \frac{\partial^2 w_0}{\partial x^2} \right) \quad (18)$$

## Analysis of Composite Cylindrical Shell Using ANSYS

The modeling of composite cylindrical shell using ANSYS software is performed for validation of the theoretical analysis. SHELL99 Linear Layered Structural Shell has been chosen. The boundary condition of simply supported is also selected as follows:

$$N_x = M_x = w = v = 0 \quad \text{at } x = 0 \text{ or } L \quad (19)$$

The shell structure is considered as a composite material with the following properties (Table1).

**Table 1.** Mechanical properties of cylindrical shell

Input parameters	Value
$L$	144 [mm]
$R$	82.5 [mm]
$E_1$	146e9
$E_2$	10.8e9
$G_{12}$	5.78e9
$\nu_{12}$	0.29
$h_i$	0.04,0.06,0.14,0.26 [mm]
$\theta$	42,40,86,25 [deg]

The distances of the rings and stringers were considered equal. The ring and stringer are made of aluminum. The specification of rings and stringers

**Table 2.** Mechanical properties of stiffeners

Input parameters	Value
$N_r$	2
$N_s$	4
$b_r = b_s$	1 mm
$d_r = d_s$	2.5 mm

### Comparison of Analytical and Numerical Results

**Table 3.** Comparative results for verification of analytical results (no stiffened)

	n	m	$P_{cri}$ [N/m]	$\sigma_y$ [Mpa]
Numerical	5	1	100031	185.2
Analytical	5	1	107235	196.1

Table 3 contains the comparison of analytical and numerical results.

As shown in Table 3, the numerical results extracted from ANSYS software approximately coincide with the analytical results with only 5 to 6 percent error for the non-stiffened cylindrical shell. Table 4 includes the same results as Table 3 for stiffened structure.

**Table 4.** Comparative results for Verification of analytical results (Stiffened)

	n	m	$P_{cri}$ [N/m]	$\sigma_y$ [Mpa]
Numerical	13	5	135041	159.6
Analytical	13	5	143523	171.7

As is listed in Table 4, the results of ANSYS software matches with an error of 5.9 to 7 percent in the analytical results of the stiffened cylinder.

In the presented method, the order of the reported values is negligible considering the engineering works. In the case of stiffened shells, the above approach could be applicable.

In order to analyze the shell stress and obtain the amount of yield stress, instead of the single pressure, a desired axial force in circumferential direction on the shell structure was applied, after obtaining the buckling load, the amount of yield stress for calculated buckling load can be determined

### The Effect of Some Parameters on Buckling Load

With MATLAB software, the effect of the number of rings and stringers on buckling load were examined, the corresponding diagram is shown in Fig.2.

From Fig. 2 it can be concluded that at small circumferential wave number (i.e  $n = 1,2$ ) the influences of number of rings and stringers are insignificant. Also, at large number of circumferential waves, the buckling load increases with number of rings and stringers. The unstiffened shell has the lowest critical load in  $n=6$  and  $m=1$ , and in our analytical procedure, buckling occurred in the same wave. Therefore, as the number of stringers increases, buckling will occur in a higher load.

By passing from the half wave of 1 to 10, at first, the buckling loads are decreases and then, they will increase. As shown in Appendix A, in the buckling equation, sinus is also involved, due to the periodic state of sinus function, the same situation has happened for buckling loads. The increase in the number of rings has a greater effect on buckling load in comparison with the increase in the number of stringers.

The effects of Length to cylinder radius ratio are also shown in Fig. 3.

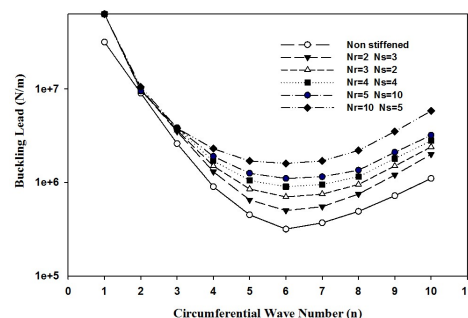

**Figure 2.** Effect of number of ring and stringer on buckling load.

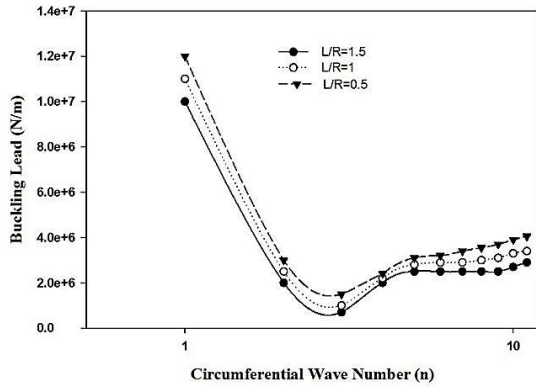

Figure 3. Effect of  $L/R$  on buckling load.

It can be found that by the increase in length to the mean radius ratio, the critical load of the stiffened cylindrical shell decreases; this trend is proportional to the ratio of thickness to radius, as the thickness of shell increases, the buckling occurs in higher loads.

### Particle Swarm Optimization (PSO)

PSO algorithm is inspired by the behavior of a group of birds, fish or insects in search of food or a certain way. Each particle expresses its position and speed using its memories and other particles, the basic steps in the PSO algorithm are as follows:

1. Generate the population of primary particles with random position values and initial random velocity.
2. Determine the new velocity vector for each particle of the population using the best previous position of each particle up to that moment, the best position experienced in the total particle population, and also the velocity vector of each particle before each other.
3. Change and improve the current position of each particle using the velocity vector of the previous position of each particle.
4. Repeat from step 2 until the desired stop criteria.

The vector of the velocity and position of each particle can be expressed by the following Equations:

$$V_k^i = wV_{k-1}^i + C_1r_1(Pbest^i - X_{k-1}^i) \tag{20}$$

$$+ C_2r_2(Gbest_{k-1}^g - X_{k-1}^i)$$

$$X_k^i = X_{k-1}^i + V_k^i \tag{21}$$

In these equations,  $i$  represents a particle, and the index  $k$  represents the number of repetitions,  $V$  represents the velocity, and  $X$  represents the position, and  $r_1$  and  $r_2$  are random numbers with uniform distribution in the interval  $\{0, 1\}$ . The coefficients  $C_1$  and  $C_2$  are particle acceleration constants.  $W$  is the coefficient of inertia.  $Pbest^i$  is the best experienced by the particle up to that moment,  $Gbest_{k-1}^g$  is the best experienced situation in the whole population that is repeated.

### Formulation of optimization problem

This section describes formulation of the optimization of the ring-stringer composite stiffened cylindrical shell. The optimization problem involves minimization of the weight of the ring-stringer composite stiffened cylindrical shell. The constraints of the problem are buckling load and stress as well as the side constraints of the design variables. The design variables and constraints are shown in Tables 5 and 6. Formulation of the optimization problem can be written as:

Minimize an objective function  $f(x) = W_t$

Subject to constraint:

$$g_j(x) \leq g_0(x) \quad j = 1, \dots, m$$

$$x_L \leq x_i \leq x_U \quad i = 1, \dots, n$$

$x$  is variable parameter and  $x_L$  is lower limitation and  $x_U$  is upper limitation as defined in Table 5.

$$g_1(x) = -F_{critical} \leq F_{ultimate}$$

Where  $F_{critical}$  is buckling load that is derived by equation 20 and is a function of variable parameters.

$$g_2(x) = \sigma_{yield} \leq \sigma_{ultimate}$$

Where  $\sigma_{yield}$  is maximum yield stress of structure that is derived by equation 22 and is a function of variable parameters. The most straightforward technique to take constraints into account is the incorporation of penalty functions to the objective function. To get faster results and better control of the optimization process, some scale factors of the function have to be introduced to minimize (f). The objective function would be as follows:

$$f(x) = f(x) + \alpha \left( \text{Max} \left\{ \frac{g_j(x)}{g_0(x)} - 1, 0 \right\} \right)$$

Where  $\alpha > 0$ .

Table 5. Design Variable Parameter

Notation	Design variable	Upper limitation	Lower limitation	Unit
$x_1, x_2, x_3$	$h_i (i = 1, 2, 3)$	1.2	0.5	[mm]
$x_4$	$N_r$	10	1	[mm]
$x_5$	$b_r$	8	2	[mm]
$x_6$	$d_r$	8	2	[mm]
$x_7$	$N_s$	10	1	[mm]
$x_8$	$b_s$	8	2	[mm]
$x_9$	$d_s$	8	2	[mm]
$x_{10}$	$\rho_{stiff}$	6500	2000	[Kg/m <sup>3</sup> ]
$x_{11}$	$\vartheta_{12}$	0.35	0.15	
$x_{12}, x_{13}, x_{14}$	$\theta_i (i = 1, 2, 3)$	90	0	[Deg]
$x_{15}$		15	2	[GPa]
$x_{16}$	$E_{11}$	450	80	[GPa]
$x_{17}$	$E_{stiff}$	200	50	[GPa]
$x_{18}$	$\vartheta_{stiff}$	0.3	0.25	[GPa]
$x_{19}$	$E_{22}$	40	10	[GPa]

**Objective function**

As indicated in the previous section, the objective function is the minimization of the total weight of the ring-stringer composite stiffened cylindrical shell ( $W_t$ ), which can be expressed as follows:

The objective function of this research is the mass, or the weight of the cylindrical shell. Total mass is a function of the mass of the shell, plus the mass of the mounted stiffeners.

$$W_t = W_{sh} + W_r + W_s \tag{22}$$

$W_t$  Is the total weight and  $W_r$  and  $W_s$  are the weights of the rings and stringers, respectively.

The weight of the cylindrical shell is obtained from Eq.23:

$$W_{sh} = \sum_{i=1}^N w_i = gL\pi\rho\{(r_N^2 - r_1^2)\}$$

$$W_{sh} = gL\pi\rho [x_1(0.165 + x_2 + x_3) + x_2(0.165 - x_1 + x_3) + x_3(0.165 - x_1 - x_2)] \tag{23}$$

$$W_{sh} = 0.165 \cdot gL\pi\rho(x_1 + x_2 + x_3)$$

Where  $r_n$  is the radius of  $n^{th}$  composite laminate. 3 layers of laminates (see Fig. 4) are assumed in the test problem of this paper. Hence, there are:  $r_1, r_2, r_3, r_4$ , and  $\rho$  is the composite density.

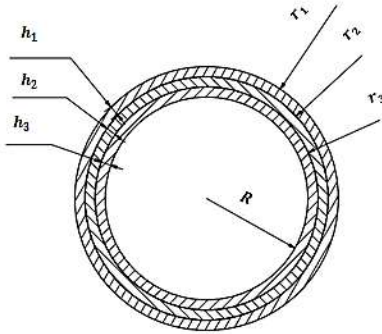

**Figure 4.** Cylindrical shell (3 laminates).

Rings weight(Fig. 1):

$$W_r = V_r \cdot \rho_r = 2\pi \cdot \rho_r \cdot N_r \cdot \left(R + \frac{h+d_r}{2}\right) \cdot b_r \cdot d_r$$

$$W_r = 2\pi \cdot \rho_r \cdot N_r \cdot \left(\frac{d}{2} + \frac{t+d_r}{2}\right) \cdot b_r \cdot d_r \tag{24}$$

$$W_r = 2\pi \cdot x_{10} \cdot x_4 \cdot \left(0.0825 + \frac{x_1+x_2+x_3+x_6}{2}\right) \cdot x_5 \cdot x_6$$

$N_r$  is the number of rings,  $d_r$  is the height of the rings,  $b_r$  is the width of the rings,  $\rho_r$  is the density of the rings and  $t$  is the thickness of the shell.

Stringer's weight is as follows:

$$W_s = V_s \cdot \rho_s = N_s \cdot \rho_s \cdot b_s \cdot d_s \cdot L$$

$$W_s = 0.144(x_7 \cdot x_{10} \cdot x_8 \cdot x_9) \tag{25}$$

$N_s$  is the number of stringers,  $d_s$  is the height of the stringers,  $b_s$  is the width, and  $\rho_s$  is the density of the stringers.

Finally, the objective function is as follows:

$$w_t = 0.165 \cdot gL\pi\rho \cdot (x_1 + x_2 + x_3) + 2\pi \cdot x_{10} \cdot x_4 \cdot \left(0.0825 + \frac{x_1+x_2+x_3+x_6}{2}\right) \cdot x_5 \cdot x_6 + 0.144(x_7 \cdot x_{10} \cdot x_8 \cdot x_9) \tag{26}$$

Constant design parameters are presented in Table 6. The design variables include: properties of the composite material ( $E_{11}, E_{22}, G_{12}, \nu_{12}$ ), properties of the stiffener's material ( $E_{stiff}, \nu_{stiff}, \rho_{stiff}$ ), number of rings  $N_r$ , number of stringer  $N_s$ , cross-section of rings  $b_r \cdot d_r$ , cross-section of stringers  $b_s \cdot d_s$ . the range of limitation is presented in Table 5.

**Table 6.** Constant Design Parameter

Input parameters	Value
Length of shell (L)	144 [mm]
Radius of shell	82.5 [mm]
Number of laminates	3
Axial load (Na)	1.5e7 [N/m]
Inner pressure (P)	20 [KPa]
Yield Stress ( $\sigma$ )	210 [MPa]

**Design Constraints**

The design constraints of the test problem are buckling load and yield stress as shown in Table 7. The buckling load is  $\frac{F_{critical}}{F_{ultimate}} \geq 1$ , and no dimensional constraint buckling means that buckling load of stiffened cylindrical shell ( $F_{critical}$ ) that is obtained with the developed MATLAB code, should be greater than the allowed load  $F_{ultimate}$ , otherwise, the stiffened cylindrical shell will be buckled.

The Yield stress is  $\frac{\sigma_{max}}{\sigma_{ultimate}} \leq 1$ , and no dimensional constraint Yield stress means that the maximum stress of stiffened cylindrical shell ( $\sigma_{max}$ ) that is obtained with the developed MATLAB code, should be smaller than the allowable stress  $\sigma_{ultimate}$ , otherwise, the stiffened cylindrical shell will reach to yield point.

**Table 7.** Design constraints

<b>Buckling Constraint</b>	$\frac{F_{max}}{F_{ultimate}} - 1 \leq 0$	$F_{max}$ is calculated by code in matlab	$F_{ultimate} = 1.5e7$
<b>Yield Stress Constraint</b>	$\frac{\sigma_{max}}{\sigma_{ultimate}} - 1 \leq 0$	$\sigma_{max}$ is calculated by code in matl	$\sigma_{ultimate} = 210e6$

**Results**

Fig. 5 shows the convergence diagram of weighting function to the number of generation based on genetic algorithms.



Due to the large difference between the scale of variable parameters (as mentioned some of them are on the scale of millimeters and some on the Giga scale), the range of all variables was set between {1, 11} and then, after obtaining the final answer of 17.776, the final values of all variable parameters that are between 1 and 11, were returned by Eq.26 to the initial scale.

For example, if the range of variables are between L and U and the obtained value from the optimization procedure is S, the final value of the parameter can be obtained as follows:

$$x = \frac{(U - L)}{10} * (S - 1) + L \tag{27}$$

After making this scale conversion for all parameters, the final and optimized values of the variables are obtained. By obtaining variables, the amount of shell weight that is the objective function in its original range can be calculated; after this stage, the objective function 4.132 is obtained. The optimum value of the particle swarm algorithm (see Fig. 6) is also performed with the same scale variation as was mentioned before. Finally, the final weighting function was achieved as 4.1280, which weighed 13.2% relative to the initial shell weighing 4.78.

After optimizing both the genetic algorithm and the particle swarm, the optimized weight decreased by 13.1% compared to the initial weight, while it has not reached critical loads and has not reached the yield stress (Table 8).

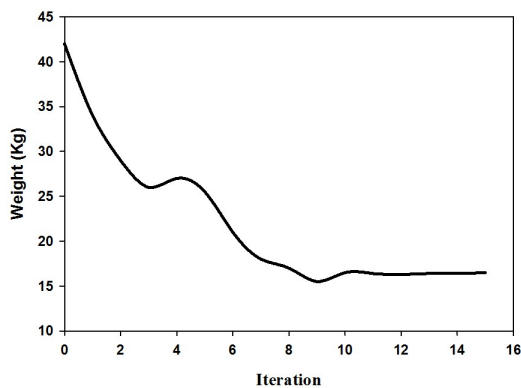

Figure 5. Convergence of weight to iteration (Genetic Algorithm)

Table 8. Result of optimization

Algorithm	Results [kg]	Error	Critical Load [N/m]	Yield Stress [Mpa]
PSO	3.128		13054403	206
GA	3.132	0.12	14067323	207.3

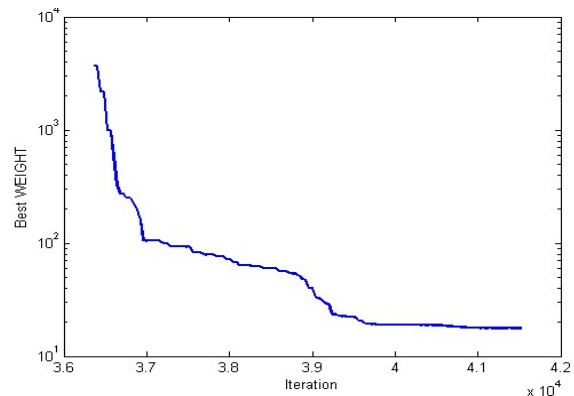

Figure 6. Convergence of weight to iteration (PSO Algorithm)

Final values of parameters are listed in Table 9.

Table 9. Final value of variable parameters

Notation	Design variable		Unit
$x_1, x_2, x_3$	$h_i (i = 1, 2, 3)$	0.69, 0.53, 0.78	[mm]
$x_4$	$N_r$	3	
$x_5$	$b_r$	4.1	[mm]
$x_6$	$d_r$	5.8	[mm]
$x_7$	$N_s$	4	
$x_8$	$b_s$	2.1	[mm]
$x_9$	$d_s$	4.7	[mm]
$x_{10}$	$\rho_{stiff}$	2604	[Kg/m <sup>3</sup> ]
$x_{11}$	$\vartheta_{12}$	0.29	
$x_{12}, x_{13}, x_{14}$	$\theta_i (i = 1, 2, 3)$	35, 42, 38	[Deg]
$x_{15}$		5.9	[GPa]
$x_{16}$		432	[GPa]
$x_{17}$	$E_{stiff}$	182	[GPa]
$x_{18}$	$\vartheta_{stiff}$	0.29	
$x_{19}$	$E_{22}$	15	[GPa]

### Conclusion

In this research, optimization of buckling load for ring/stringer stiffened cylindrical laminated composite shells subjected to axial compression was considered. The maximum strength to weight ratio of these structures was assumed. Evolution algorithms are employed due to discrete design variables and also the need for global searches. In this study, PSO algorithm has been utilized in addition to the genetic algorithm. The constraints were assumed as buckling load and the yield stress. Governing equations for composite stiffened cylindrical shell using the principle of minimum energy were written relative to the Ritz coefficients. For kinematic relations of the Love Kirchhoff approximation, stiffeners are considered as separate elements; then, the conjugation relationship between the stiffeners and the shell was applied. Shell loading is assumed to be internal and axial force and the boundary

conditions were simply supported. Related constraints were reconsidered in  $m$  separated MATLAB files and are called in each replication and checked by an algorithm in which the direction of the objective function in the region was acceptable. After optimizing both the genetic algorithm and the particle swarm, the optimized weight decreased by 13.1% compared to the initial weight, while it did not reach critical buckling loads and did not reach the yield stress. Also, the final values of optimization by each genetic and particle accumulation were very close, but the particle swarm approach was much faster than the genetic method.

### Appendix

$$\alpha_{11} = L\pi^2 \left\{ -N_a R \lambda^2 - \frac{A_{66} n^2}{R} - A_{11} R \lambda^2 + \frac{B_{66} n^2}{R} + \frac{D_{66} n^2}{4R^3} \right\}$$

$$\alpha_{12} = L n \pi^2 \lambda \left\{ A_{12} + A_{66} + \frac{B_{12}}{R} + \frac{B_{66}}{R} - \frac{3D_{66}}{4R^2} \right\}$$

$$\alpha_{13} = L\pi^2 \lambda \left\{ A_{12} + B_{11} R \lambda^2 + \frac{B_{12} n^2}{R} + \frac{2B_{66} n^2}{R} - \frac{D_{66} n^2}{R^2} \right\} + \frac{1}{2} N_s L \pi^3 A_3 z_3 (E_s + N_a)$$

$$\alpha_{21} = \alpha_{12}$$

$$\alpha_{22} = L\pi^2 \left\{ -N_a R \lambda^2 - \frac{D_{22} n^2}{R^3} - \frac{2B_{22} n^2}{R^2} - \frac{A_{22} n^2}{R} - \frac{4B_{66} \lambda^2}{R} - A_{66} R \lambda^2 - \frac{4D_{66} \lambda^2}{R} \right\} - \frac{2n^2 \pi^2 A_r E_r}{R} \sum_{k=1}^{N_r} (\sin \lambda x_k)^2 - \frac{1}{2} N_s L \pi^2 A_s N_a$$

$$\alpha_{23} = L n \pi^2 \left\{ -\frac{A_{22}}{R} - B_{12} \lambda^2 - \frac{B_{22} n^2}{R^2} - 2B_{66} \lambda^2 - \frac{B_{22}}{R^2} - \frac{D_{22} n^2}{R^3} - \frac{D_{12} \lambda^2}{R} - \frac{4D_{66} \lambda^2}{R} \right\} - \frac{2n^2 \pi^2 A_r E_r}{R} \sum_{k=1}^{N_r} (\sin \lambda x_k)^2 - \frac{N_s L n \pi A_s z_3 \lambda^2 N_a}{2R} - \frac{2N^3 \pi^2 A_r z_r E_r}{R^2} \sum_{k=1}^{N_r} (\sin \lambda x_k)^2$$

$$\alpha_{31} = \alpha_{13}$$

$$\alpha_{32} = \alpha_{23}$$

$$\alpha_{33} = L\pi^2 \left\{ -N_a \lambda^2 R - 2B_{12} \lambda^2 - \frac{D_{22}}{R^3} - \frac{2D_{22} n^2}{R^3} - \frac{D_{22} n^4}{R^3} - \frac{2B_{22}}{R^2} - \frac{A_{22}}{R} - \frac{2D_{12} \lambda^2}{R} - \frac{2D_{12} \lambda^2 n^2}{R} - \frac{4D_{66} \lambda^2 n^2}{R} - D_{11} R \lambda^4 \right\} - \left\{ \frac{2n^4 \pi^2 I_{or} E_r}{R^3} + \frac{2\pi^2 A_r E_r}{R} \right\} \sum_{k=1}^{N_r} (\sin \lambda x_k)^2 - \frac{2n^2 \pi^2 \lambda^2 G_r J_r}{R} \sum_{k=1}^{N_r} (\cos \lambda x_k)^2 - \frac{1}{2} L N_s \pi \lambda^4 I_{or} (E_s + N_a) - \frac{4n^2 \pi^2 A_r E_r z_r}{R^2} \sum_{k=1}^{N_r} (\sin \lambda x_k)^2 - \frac{P L \pi (n^2 - 1)}{4}$$

### References

[1] Simitses, G. J., "Buckling and Postbuckling of Imperfect Cylindrical Shells: A Review", *Applied Mechanics Reviews*, Vol. 39, No. 10, pp. 1517-1524, 1986.

[2] Akbulut, M. and F. O. Sonmez (2008). "Optimum design of composite laminates for minimum thickness." *Comput. Struct.* 86(21-22): 1974-1982.

[3] Lopez, R., et al. (2009). Optimization of laminated composites considering different failure criteria.

[4] Coburn, B. H., et al. (2014). "Buckling analysis of stiffened variable angle tow panels." *Composite Structures* 111: 259-270.

[5] Ye, F., et al. (2017). "Variable stiffness composite material design by using support vector regression assisted efficient global optimization method."

*Structural and Multidisciplinary Optimization* 56(1): 203-219.

[6] Ganguli, R. (2013). *Optimal Design of Composite Structures: A Historical Review*.

[7] Bahubalendruni, M. V. A. R. and B. B. Biswal (2014). Study of optimization of composite structures with respect to industrial applications. 2014 IEEE 8th International Conference on Intelligent Systems and Control (ISCO).

[8] Henrichsen, S. R. (2015). Optimization of Laminated Composite Structures, Aalborg Universitetsforlag.

[9] Koide, R. M. and M. A. Luersen (2013). "Maximization of Fundamental Frequency of Laminated Composite Cylindrical Shells by Ant Colony Algorithm." *Journal of Aerospace Technology and Management* 5: 75-82.

[10] L  n  , F., et al. (2009). "An advanced methodology for optimum design of a composite stiffened cylinder." *Composite Structures* 91(4): 392-397.

[11] Muc, A., "Transverse shear effects in discrete optimization of laminated compressed cylindrical shells", *Composite Structures*, Vol. 38, No. 1, pp. 489-497, 1997/05/01, 1997.

[12] Paweł Forys, Optimization of cylindrical shells stiffened by rings under external pressure including their post-buckling behaviour, Institute of Applied Mechanics, Cracow University of Technology, al. Jana Pawła II 17, 31-864 Kraków, Poland.

[13] Khong, P., "Optimal Design of Laminates for Maximum Buckling Resistance and Minimum Weight", 1999.

[14] Walker, M., Smith, R. E., "A technique for the multiobjective optimisation of laminated composite structures using genetic algorithms and finite element analysis", *Composite Structures*, Vol. 62, No. 1, pp. 123-128, 10//, 2003.

[15] Adams, D. B., Watson, L. T., G  rdal, Z., Anderson-Cook, C. M., "Genetic algorithm optimization and blending of composite laminates by locally reducing laminate thickness", *Advances in Engineering Software*, Vol. 35, No. 1, pp. 35-43, 1//, 2004.

[16] MH Shojaeifard, R Talebitooti, A Yadollahi, Optimization of sound transmission through laminated composite cylindrical shells by using a genetic algorithm, mechanics of composites materials, September 2011, 47:481.

[17] Park, J. H., Hwang, J. H., Lee, C. S., Hwang, W., "Stacking sequence design of composite laminates for maximum strength using genetic algorithms", *Composite Structures*, Vol. 52, No. 2, pp. 217-231, 5//, 2001

[18] A. Gharib, Shakeri M, , Stacking sequence optimization of laminated cylindrical shells for buckling and free vibration using genetic algorithm and neural networks, 2nd International Conference on Engineering Optimization, September 6 - 9, 2010, Lisbon, Portugal.



- [19] Sadeghifar, M., Bagheri, M., Jafari, A. A., "Multiobjective optimization of orthogonally stiffened cylindrical shells for minimum weight and maximum axial buckling load", *Thin-Walled Structures*, Vol. 48, No. 12, pp. 979-988, 12//, 2010.
- [20] R. Talebitooti, MH Shojaeefard, S Yarmohammadisatri, Shape design optimization of cylindrical tank using b-spline curve, *Computers and Fluids*, Vol 109, 10 March 2015, Pages 100-112.
- [21] Kennedy, J., Eberhart, R., "Particle swarm optimization", in *Proceeding of, 1942-1948* vol.4.
- [22] P. Y. Jiang, Z. M. Lin, J. Xu, and J. Q. Sun, "A Particle Swarm Optimization Algorithm for Minimizing Weight of the Composite Box Structure," in *Advanced Materials Research*, 2012, vol. 430, pp. 470-475.
- [23] I. C. Trelea, "The particle swarm optimization algorithm: convergence analysis and parameter selection," *Inf. Process. Lett.*, vol. 85, no. 6, pp. 317-325, 2003.
- [24] S. Suresh, P. B. Sujit, and A. K. Rao, "Particle swarm optimization approach for multi-objective composite box-beam design," *Compos. Struct.*, vol. 81, no. 4, pp. 598-605, 2007.
- [25] N. Chang, W. Wang, W. Yang, and J. Wang, "Ply stacking sequence optimization of composite laminate by permutation discrete particle swarm optimization," *Struct. Multidiscip. Optim.*, vol. 41, no. 2, pp. 179-187, 2010.
- [26] Akl, W., Ruzzene, M., Baz, A., "Optimal design of underwater stiffened shells", *Structural and Multidisciplinary Optimization*, Vol. 23, No. 4, pp. 297-310, 2002.
- [27] Tian, J., Wang, C. M., Swaddiwudhipong, S., "Elastic buckling analysis of ring-stiffened cylindrical shells under general pressure loading via the Ritz method", *Thin-Walled Structures*, Vol. 35, No. 1, pp. 1-24, 9//, 1999.
- [28] Rinehart, S. A., Wang, J. T. S., "Vibration of simply supported cylindrical shells with longitudinal stiffeners", *Journal of Sound and Vibration*, Vol. 24, No. 2, pp. 151-163, 1972/09/22, 1972.
- [29] Lim, C., Ma, Y., "Computational p-element method on the effects of thickness and length on self-weight buckling of thin cylindrical shells via various shell theories", *Computational mechanics*, Vol. 31, No. 5, pp. 400-408, 2003.